

MASTER 251C

Model:M251C

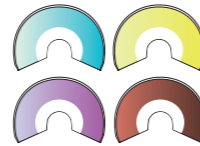

CMY+CTO

BEAM+WASH, CMY+CTO, 1.8° Angle, Ø160mm Front Lens, Front Neon Ring, 2 Prism Wheels, Continuous PAN/TILT

The MASTER 251C is an ultra compact and light weight stylish moving head beam light designed with a full CMY color mixing system and CTO color correction. It features an OSRAM SIRIUS HRI 251W lamp, integrated with a set of unique high resolution optical system (160cm front lens).

The fixture features 1.8° beam angle which helps to provide ultra long throw solid beam effect. The front ring strip light delivers a magic lighting effect created by 30*0.2W 3-IN-1 SMD RGB LEDs. The MASTER 251C is designed with a range of effects: 13 static gobos, 13 dichroic colors, 6-Color Wheel, 2 prism wheels, frost, focus, etc. It provides 360° continuous fast and smooth PAN/TILT movement with variable speed which delivers even more vivid visual effect to the show. The fixture supports DMX, RDM (Remote Device Management).

The fixture's exterior housing is beautifully balanced basing on a modern design philosophy with supremely harmonious interior structure for remarkable control. The sculpted body of the MASTER 251C achieves more than just a striking look. The 2*1/4 turn fastening omega clamps, available for vertical and horizontal plug-in, make installations fast and easy.

It's fast and quiet operation moving head beam. It's a perfect option for indoor application like large scale live concerts, TV productions, road shows, conference halls, clubs, etc.

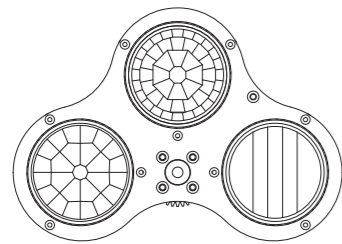

Prism 1: 3 different prisms, 5-Facet linear prism/8+16-Facet circular prism/8+16+24-facet circular prism with variable speed and direction

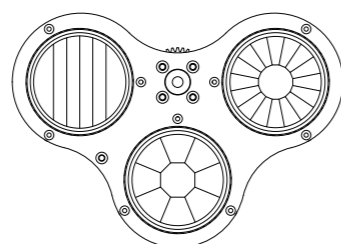

Prism 2: 3 different prisms, 6-Facet linear prism/8-facet circular prism/16-facet circular prism with variable speed and direction



6-Color Wheel

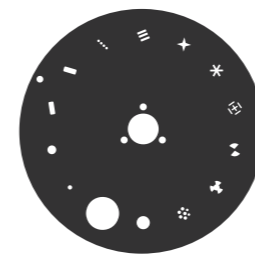

Static gobo

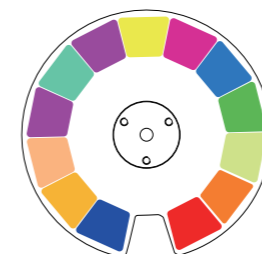

Color wheel

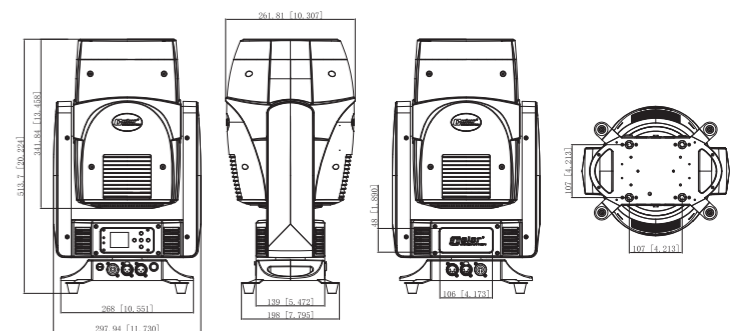

Dimensions

Light Source

Source:
1*OSRAM SIRIUS HRI 251W Lamp
30*0.2W 3-IN-1 RGB LEDs
Color Temperature: 7800K
CRI: ≥80
Flicker free operation for broadcast TV and FILM
Life Span: 3000H
The life span may vary depending on several following factors but not limited to: Environmental Conditions, Power/Voltage, Usage Patterns (On-Off Cycling), Control, and Dimming)

Optics

A set of high resolution and precise optics
Ø160mm Front lens
1.8° Beam angle
Smooth and precise linear focus

Movement

PAN: 2 modes
1. 360° Continuous movement
2. 540° (8/16 bit)
TILT: 2 modes
1. 360° Continuous movement
2. 270° (8/16 bit)
Fast, quiet, smooth and precise 3-Phase motors
Smooth, fast and precise resolution for PAN/TILT movement with low noise operation
Scan position memory, auto reposition after unexpected movement
PAN/TILT reversible

Color System

Full CMY color mixing system
CTO color correction
1 Color wheel with 13 dichroic colors plus open
Variable direction rainbow effect with speed adjustable
6-Color wheel with variable direction and speed control

Strip Effect

1- ring strip effect with different built-in macro effects (variable speed control)

Gobo System

1 Static gobo wheel with 13 gobos plus open

Prism System

2 Prism wheel design
Prism 1: 3 different prisms, 5-Facet linear prism/8+16-Facet circular prism/8+16+24-facet circular prism with variable speed and direction
Prism 2: 3 different prisms, 6-Facet linear prism/8-facet circular prism/16-facet circular prism with variable speed and direction
Prism indexing
Prism overlay (prism morphing)

Strobe Effect

0-20Hz shutter/strobe effect with variable speed
Preset variable/random strobe and dimming pulse effect

Wash System

Even and soft coverage

Dimming System

0-100% Smooth linear dimming

Control System

25 DMX channels USITT DMX-512 DMX512, master-slave, or auto operation
RDM recorder and edit function integrated RDM available (Remote Device Management)
Art-NET (Optional)
Wireless receiver system (Optional)
Shielded input signal protection for stable signal without interference
RJ45 etherCON IN/OUT (Optional with Art-Net)
3-Pin and 5-pin XLR DMX connectors IN/OUT

Software Update

Software up-datable through DMX connectors
Multi units up-datable in daisy chain

Display System

1.44" TFT LCD display
5 Control buttons
180° Reversible for LCD display
Display auto OFF
DMX signal monitoring indicator

Cooling System

Advanced low noise cooling system integrated aluminum and fan
Constant temperature readout and management function
Over temperature protection management

Power Supply

Electronic ballast: PT-SIRIUS 260W
Electronic supply with active PFC
AC100-240V 50/60Hz
PowerCON IN/ OUT with fuse
375W Power consumption

Housing

High tension molded fire proof housing with PA6+fiberglass
Skeleton made of aluminum and steel metal plates
Two side handles on base
Exterior finish: Black

Installation

2*1/4 turn fastening Omega Clamps (Adaptable vertically and horizontally)
1* Safety attachment point

Operating Condition

Operating positions: all (device on floor or fixed to a support)
-25°C to 45°C ambient temperature
IP20 protection rating

Compliance

CE
2014/35/EU - Safety of electrical equipment supplied at low voltage (LVD)
2014/30/EU - Electromagnetic Compatibility (EMC)
2011/65/EU - Restriction of the use of certain hazardous substances (RoHS)

Weight

N.W.: 15.9kg
G.W.: 17.7kg

Dimensions

Product Dimensions:
261.8(D)*297.9(W)*513.7(H)mm
Packing Dimensions:
410(D)*680(W)*365(H)mm